

SILVERSTONE

PRO LINE



www.silverstone.se



Pro Line Quick Lift

Hand pallet truck with automatic quick lift function that lifts the pallet in one stroke. Equipped with a built-in overload valve. Rubber steering wheels with boogie polyurethane fork wheels. Lift speed 25/10 mm/stroke (quick lift up to 150 kg/normal lift over 150 kg). Lifts from 85-205 mm. Capacity is 2300 kg.

Q7715-1150-R



Pro Line Hand Pallet Truck

A solid construction with a well established strong hydraulic pump. Bearing at the top of the chassis and proper grease nipples be on the entire chassis. This makes Pro-Line to one of the most affordable forklift on the market. Available in lengths 910 and 1150 mm and various wheel options.

HG15-1150



Hand Pallet Truck Electronic Scale 2000 kg

Hand pallet truck with electronic scale for many applications. Stationary and mobile weighing or normal pallet truck duties. Time saving operating, versatile handling and efficiency in the same hand pallet truck. Secure fixation of the forks and the load cells to the bottom chassis. The four (4) load cells enables very accurate weighing of even and uneven loads.

- Small compact weighing unit specially designed for mobile weighing.
- Low self weight = easy to manoeuvre
- IP65 built = stands water wash-off.
- High definite display, 18 mm high numbers.
- Weighing accuracy 0,1% of loaded weight.
- Grade 1kg.
- Weighing unit is powered by 4 1,5V AA batteries. Extern charger is included, for ZFP20S.
- Tara function which enable user to add or withdraw from net weight.
- Operating temperature: -10 to 40 degree C.

Electronic Scale ZF20S-Y

Model	Capacity (kg)	Fork Width (mm)	Fork Length (mm)	Fork Height min/max (mm)	Weight (kg)	Wheels	Price
HG12-910/1150	2500	520/160	910 el. 1150	85/200	70/75	Single Nylon	
HG13-910/1150	2500	520/160	910 el. 1150	85/200	70/75	Single PU	
HG14-910/1150	2500	520/160	910 el. 1150	85/200	70/75	Boggie Nylon	
HG15-910/1150	2500	520/160	910 el. 1150	85/200	70/75	Boggie PU	
Q7715-1150-R	2300	530/150	1150	85/205	75	Boggie PU	
ZF20S-Y	2000	555/180	1150	90/210	117	Boggie PU	
ZFP20S-Y	2000	555/180	1150	90/210	118	Boggie PU	

• Polyurethane wheel = PU

Hand pallet trucks Pro Line also available in: Stainless, Galvanized, Low profile. Several fork sizes. Call for more info!

Full-Electric Compact Walkie / 1500 kg

RA15 is a very compact and strong full electric pallet truck, especially suitable in narrow aisles and in the back of lorries. The minimal Turning circle enables very smooth handling together with the "tortoise-mode", stepless speed control. Charger is of course built in and the tiller/handle is the latest, best ergonomic, design from REMA, Germany. 205° steering in combination with creep speed function enables driving in the most confined areas, even with handle in upright position.

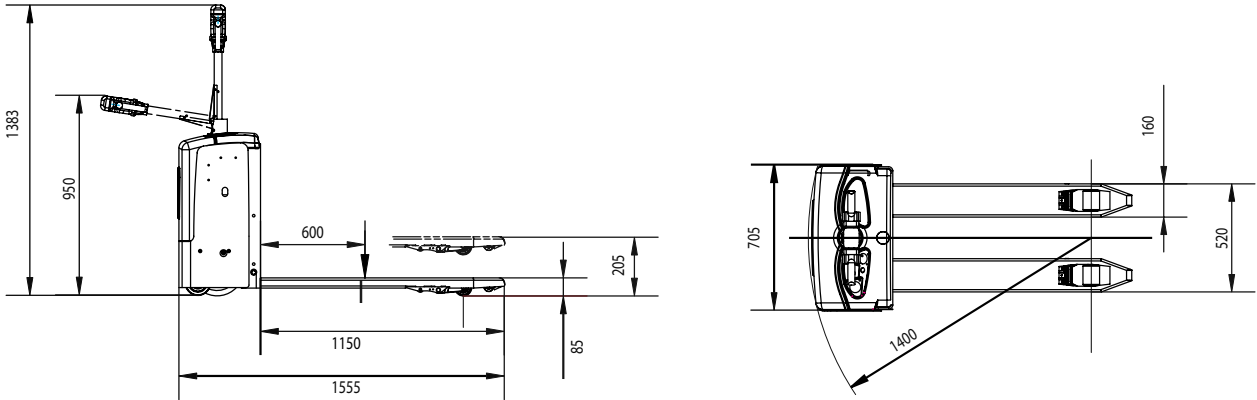

Model	RA15-Y	
Capacity	(kg)	1500
Load Centre	(mm)	600
Fork Height, min-max	(mm)	85-205
Fork Length	(mm)	1150
Fork Width, outer-individual	(mm)	520/160
Wheel Base	(mm)	1170
Turning Radius	(mm)	1400
Travel Speed, load / no load	(km/h)	4.0/5.0
Lift Speed, load / no load	(mm/s)	22/42
Lower Speed, load / no load	(mm/s)	40/30
Drive Wheel diameter	(mm)	250x80
Drive Motor / Lift Motor	(W)	750/800
Battery	(Ah/V)	70/12x2
Charger (included)	(Ah/V)	25/24
Rear Part Dimensions L2xW	(mm)	405x705
Overall Dimensions LxH	(mm)	1555x1383
Weight + battery	(kg)	270 + 17
Price		

RA15-Y Full-Electric

High Lifter Electric / Battery

The electric high lifter makes all types of handling safe and easy. The battery box is positioned between the scissor unit and the lift cylinder, which makes the high lifter compact and easy to operate. This model has a built in charger with the largest battery as standard (60Ah/12V), which gives many working hours per charging. SE1056 has high lift and lowering speeds. The reliable power unit comes from HPI, France. This top quality and high performance high lifter has a single lifting cylinder with a high upper part.



High Lifter Quick Lift / Manual

This top quality and high performance high lifter has a single lifting cylinder with a high upper part, this makes the high lifter truck very reliable. It means also less risk for leakage, due to reduced wear on the seals. Automatic quick lift function up to 250 kg.

Model		HB1056M	HB1056E
Version		Manuel pump	Electric pump
Capacity	(kg)	1000	1000
Fork Width	(mm)	560 / 160	560 / 160
Fork Length	(mm)	1190	1190
Lifting Height	(mm)	800	800
Lifting Speed	(mm/slag)	12 / 28	42 / 73 (mm/sec)
Weight	(kg)	128	150
Wheels		Polyurethane	Polyurethane
Price			

Manual high lifter also available with 1500 long forks.

Manual Stacker with double action pump

KS1015 / KS1023

Our very popular manual stacker with double action pump cylinder enables faster lifting. Pulling-/Steering- arm is chain connected with steering wheel which makes this product very easy to manoeuvre with a turning radius 180 degrees. Complies to EN1757 including CE approvals.

Double Action
Compact and Strong
Capacity 1000 kg



Model		KS1015-Y	KS1023-Y
Capacity	(kg)	1000	1000
Lifting height min.-max.	(mm)	90-1500	90-2300
Lifting speed, quick/norm.	(mm)	30/-	30/-
Fork length	(mm)	1150	1150
Fork width	(mm)	540	540
Fork wheel	(mm)	Ø78 x 80	Ø78 x 80
Steering wheel	(mm)	Ø150x55 nylon	Ø150x55 nylon
Dimensions	(mm)	1600x700x1950	1600x700x1900
Weight	(kg)	240	270
Price			

Semi-Electric Stacker Heavy-Duty / 1000 kg

Applications with intensive handling and continuous lifting, requires high capacity electric stackers. The MS-range has a compact design and small turning radius, with the largest battery 120Ah/12V as standard. This gives many working hours per charging and high lifting/lowering speeds. Easy and smooth steering makes the stackers safe and easy-to-operate. Therefore the MS-range is the perfect choice for high productivity requirements in confined spaces. Four lifting heights 900, 1600, 2400 and 3300 mm. Nylon wheels only. Lift capacity 1000 kg at LC 600 mm. Conforms to EN 1726-1:2001 standards

Full Capacity 1000 kg
Compact and Reliable
Big Battery 120Ah
Three Lift Heights

The MS have a welded and reinforced chassis, Simplex 1-stage lifting mast with C-section profiles, dual chains and single lift cylinder, maintenance-free bushings and sealed bearings (RS) in lift mast, fork carriage and wheels. Separate hydraulic system with protected motor, pump, valves and tank. This gives a long and trouble-free life time.

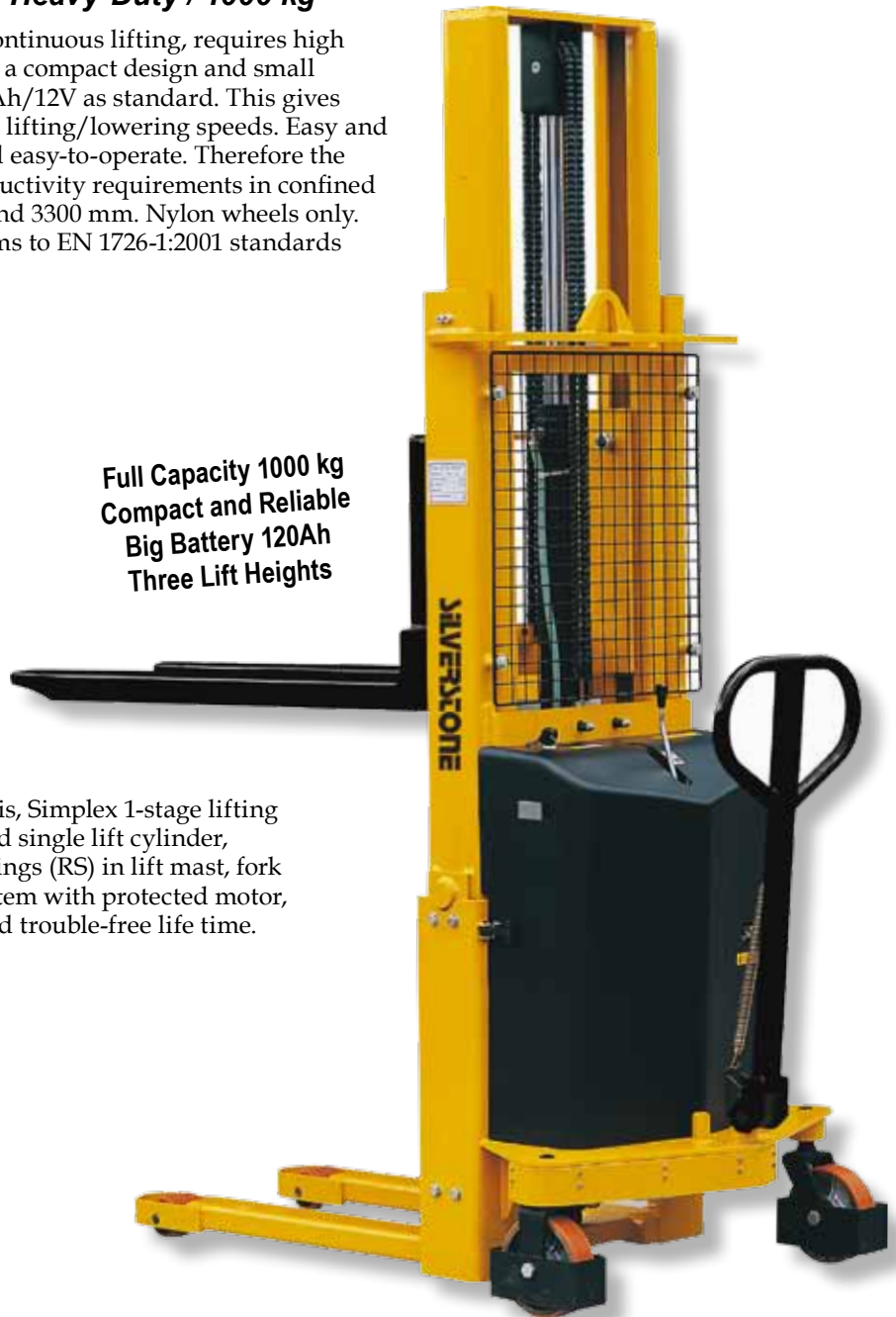

Model		MS1016-Y	MS1033-Y
Lifting Mast		Simplex 1-stage	Simplex 1-stage
Capacity	(kg)	1000	1000
Load Center	(mm)	600	600
Lift Height, min-max	(mm)	85-1600 (free-lift)	85-3300
Fork Width, outer-inner	(mm)	540 / 160	540 / 160
Fork Length	(mm)	1150	1150
Lifting Speed, no load-load	(mm/s)	120-95	120-95
Lifting Motor	(W)	800	800
Battery	(Ah/V)	120 / 12	120 / 12
Charger	(Ah/V)	15 / 12	15 / 12
Steer Wheels	(mm)	Ø180x50	Ø180x50
Load wheels	(mm)	Ø80x70 (single)	Ø80x70 (single)
Turning Radius (outside)	(mm)	1600	1600
Dimension (LxWxH)	(mm)	1820x800x2130	1820x1090x2225
Weight (Incl. Battery)	(kg)	420	550
Price			

Full Elektric Stacker 1000 kg

FK-series is a complete stacker with high quality .

Control system from Curtis. Handle is the latest, best ergonomic, design from REMA, Germany.

Drive unit with electromagnetic brake.

Compact design for easy operation in shops and factories with limited space.

Overall width is only 800 mm and with 205 degree steering, this stacker provides exelent maneuvering quality.



Model		FK1016	FK1029
Capacity	(kg)	1000	1000
Load Center c	(mm)	600	600
Max. Fork Height h3	(mm)	1600	2900
Min. Fork Height	(mm)	90	90
Fork Length l	(mm)	1150	1150
Overall Length L	(mm)	1850	1850
Truck Length incl. Fork Face L2	(mm)	700	700
Over Width B	(mm)	800	800
Closed Mast Height h1	(mm)	2080	2090
Free Lift	(mm)	-	90
Extended Mast Height h4	(mm)	2300	3600
Fork Overall Width M	(mm)	540	540
Load Distance X	(mm)	365	365
Wheel Base Y	(mm)	1260	1260
Individual Fork Width	(mm)	160	160
Ground Clearance	(mm)	30	30
Front Load Wheel	(mm)	PU ø80x60	PU ø80x60
Rear Steering Wheel	(mm)	PU ø150x54	PU ø150x54
Turn Radius Wa	(mm)	1500	1500
Lifting Speed (with/without load)	(mm/s)	140/100	140/100
Lowering Speed (with/without load)	(mm/s)	105/110	105/110
Travelling Speed (with/without load)	(mm/s)	3,5/5,0	3,5/5,0
Motors Lifting	(KW/V)	2,2/24	2,2/24
Motors Traveling	(KW/V)	1,2/24	1,2/24
Battery	(Ah/V)	160/24	160/24
Charger	(A/V)	16/24	16/24
Weight (Incl. Battery)	(kg)	645	670
Price			

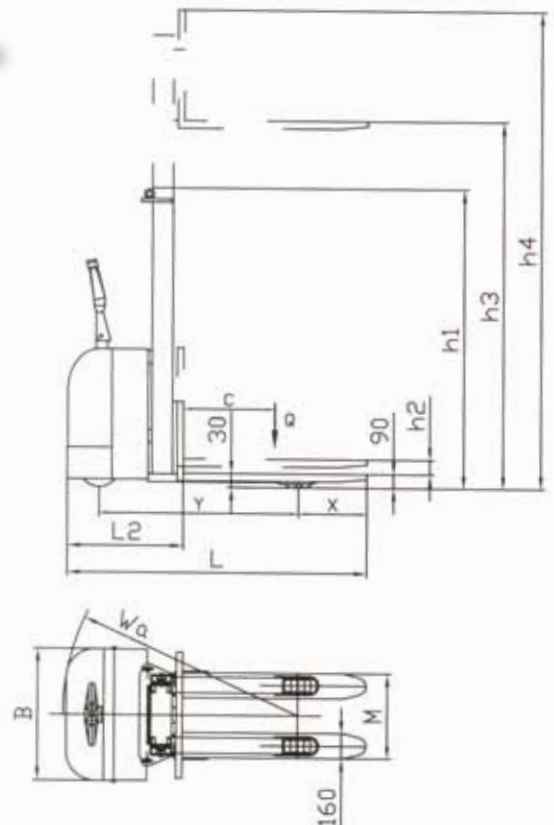



Fork Extensions to Forklift's

The simple but effective way of lengthening your forks to handle longer loads safely. Heavy duty steel construction, fit onto forks up to 50 mm thickness. Steel retaining strap prevents extensions from sliding off during use. The extension is shaped as a U-beam.

Model		EX604	EX605	EX725	EX726	EX825	EX826	EX926
Fork Length	(mm)	1525	1525	1830	1830	2000	2000	2440
Fork Width	(mm)	100	125	125	150	125	150	150
Weight	(kg)	44	53	59	64	70	73	86
Price								

Hydraulic Forklift Jack / Stands

Jacks and stands specially designed for forklift trucks. The HFJ-range has a high capacity and a rugged construction. Extra low pick-up position with double 2-position lift pad levels for hard-to reach places under low profile forklift trucks. Unique design of the hydraulic pump incl. high-quality seal kits and built-in overload protection valve. Removable handle and compact size. Capacity 4.000 or 7.000 kg, lift range 65-406/420 mm.



Spare parts

Silverstone has a big stock for spare parts. Experienced staff always ready for the best support to our customers.





Silverstone Group

Silverstone was established in 1995 and is today one of the biggest distributor for light material handling equipment in Europe. Our goal is to provide a broad mix of price worthy products within all segments. We also aim to have all products in stock to provide quick deliveries. Head office is located in Ljungby, Sweden, where you also find our 11.000sqm warehouse. We are today represented in 28 countries through our dealers. Please contact our dealer below to get more information.

Silverstone Pro Line Serie

Pro Line is a series of products designed primarily for industry and tougher handling. We have in this series taken on the requests emerged from quality, design, flexibility, spare parts, etc. All products in Pro Line series are assembled and tested thoroughly at our warehouse in Ljungby. Quality will be in focus and as our costumer you can trust that we do everything to have a product that complies with your expectations.

Contact • +46 372 694 30 • www.silverstone.se
